

Round Timber Transport

Guidelines for Hauliers and Drivers



Forest Industry Transport Group

July 2017

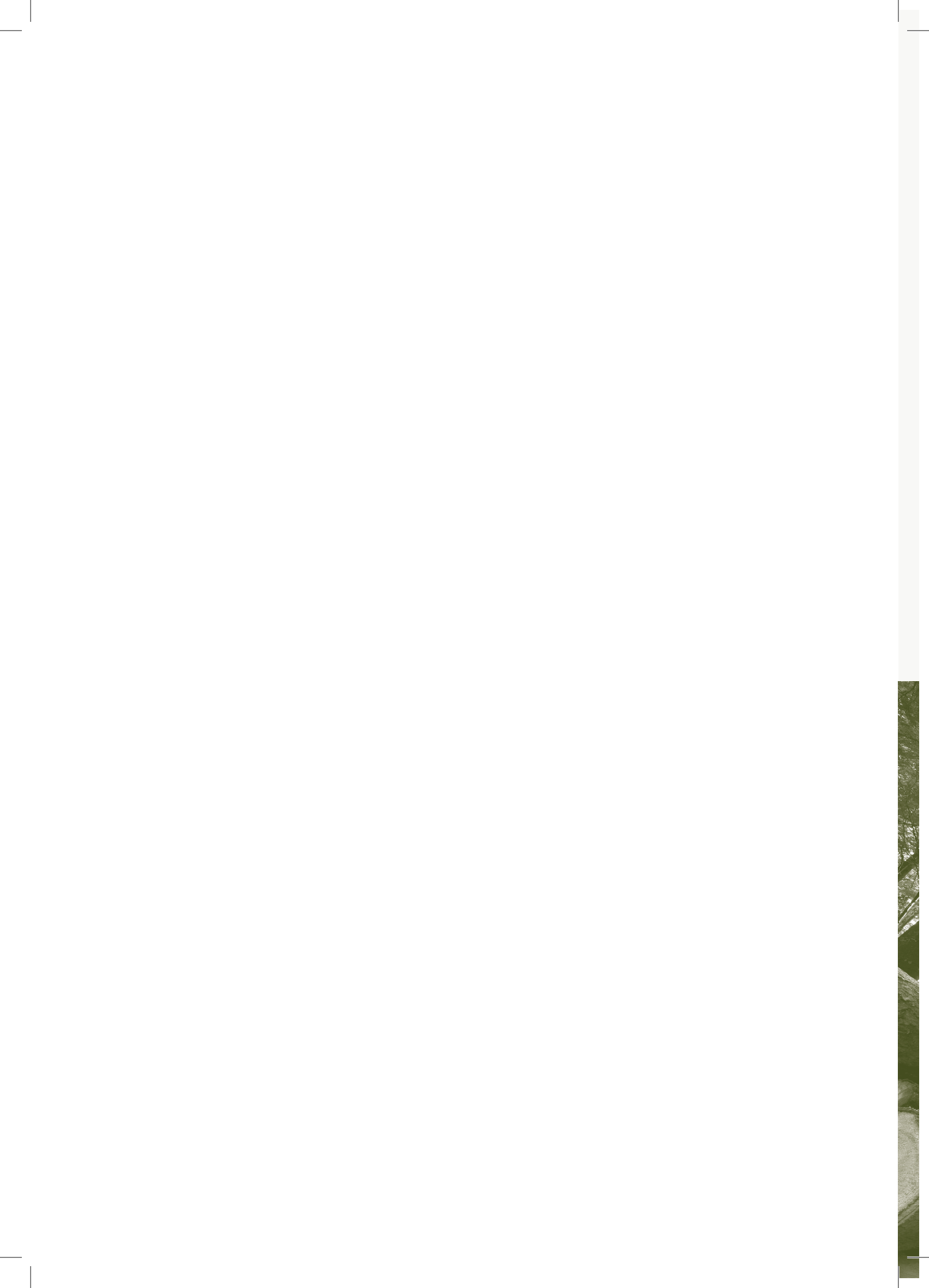

CONTENTS

Page

Foreword	i
Acknowledgments	ii
Glossary	iii
1. Responsibilities	01
2. Vehicle Legal Requirements and Compliance	03
3. Load Securing Systems	05
4. Loading Vehicles	11
5. Securing the Load	13
6. Transporting the Load from the Forest	15
7. Unloading Vehicles	16
<i>References and Websites</i>	18
<i>Legislation and Standards</i>	19



Foreword

The transport of round timber presents many challenges and none more so than Load Securing. Round timber transport involves various different log specifications, lengths, diameters, and the weight will vary depending on moisture content. The amount of bark removal on the logs will also influence decisions involving load securing, particularly in the springtime when bark is more easily stripped by mechanical harvesting. The first part of the journey after the driver leaves the forest is usually on poor quality tertiary roads which presents further challenges. The Forest Industry Transport Group published a guide on timber transport in 2014 to assist hauliers and other stakeholders in meeting these challenges¹.

In 1963 the Department of Local Government issued the Road Traffic (Construction, Equipment and Use of Vehicles) Regulations and it included a paragraph on load security². This stated that “every load carried by a vehicle in a public place shall be of weight and size and so distributed, packed, adjusted and attached to the vehicle, that, so far as can reasonably be foreseen, no danger is liable to be caused and that there is no interference with the stability of the vehicle”. This law is still in operation today. At that time the maximum gross vehicle weight was 32 tons. It is not surprising therefore that there is greater focus on load security now as the current Gross Vehicle Weights have increased by almost 50% since then to 46 tonnes, and there is much more traffic on the roads and increasing volumes of timber being transported.

In 2017 the Health and Safety Authority issued an information sheet on the securing of round timber on vehicles³. This follows a number of Load Series Safety information sheets on securing loads of steel, precast concrete and plant/machinery and is the first such document to specifically address the issue of securing round timber.

A new European Directive on vehicle roadside inspections is coming into operation, and this includes a specific section on load security⁴. There is a comprehensive list of load securing items which will be part of the roadside inspection, e.g. stanchions, lashing points, restraining method, ratchets tensioners.

A further relevant publication on load securing and securing devices is the Health and Safety Authority / IRU guidelines⁵.

It is against this back drop that the Forest Industry Transport Group have decided to publish this additional guidance document to provide the driver and vehicle operator with the relevant information to enable them to comply with technical and safety aspects of timber transport.

These guidelines have been prepared on behalf of the Forest Industry Transport Group FITG.

1 Forest Industry Transport Group – Managing Timber Transport, Good Practice Guide, 2014

2 SI No 190 of 1963 – Road Traffic (Construction, Equipment and Use of Vehicles) Regulations 1963

3 Health and Safety Authority – Load Safety Series, Information Sheet on Safe Load Securing of Round Timber

4 Directive 2014/47/EU on the technical roadside inspection of the roadworthiness of commercial vehicles circulating in the Union and repealing Directive 200/30/EC

5 Health and Safety Authority/IRU – International Guidelines on Safe Load Securing for Road Transport

Acknowledgments

This guideline document has been produced by the Forest Industry Transport Group (FITG) following consultation with group members and industry stakeholders.

FITG would like to acknowledge the work of Mr. Michael Joyce (logistics consultant) for his work in the compilation of this document. Consultations took place with various organisations including;

- HSA
- The Forest Service, Department of Agriculture Food & the Marine (DAFM)
- Department of Transport Tourism & Sport (DTTAS)
- Coillte
- Irish Forestry and Forest Products Association (IFFPA)
- Teagasc Forestry
- Timber Haulage Contractors

Special thanks to the working group consisting of John Lyons (Coillte), Gerry McMorrow (McMorrow Haulage) Des Phelan (Coillte), and Scott Robinson (Robinson Trailers).

The support provided by the Forest Service, Department of Agriculture Food & the Marine towards the costs associated with the production of the guideline document is also acknowledged.

Contacts

Des Phelan - FITG Chairman

des.phelan@coillte.ie

Fionán Russell - FITG Secretary

fionanptr@eircom.net

Michael Joyce - Logistics Consultant

mgjoyce@eircom.net

Glossary

Bunk – a “U” shaped frame including uprights and a horizontal cross member for securing round timber.

Stanchions – also called bolsters or uprights.

Lashing points – point on the vehicle to which the load strap/chain is attached.

Standard Hand Force (S_{HF}) – Expressed in daN , this is the force exerted by hand on the tensioner (ratchet) without any additional levers or attachments.

Standard Tension Force (S_{TF}). Expressed in daN – this is the residual force after physical release of the handle of the tensioning device, as a result of using S_{HF} .

Lashing Capacity (LC) Expressed in daN – Maximum allowed force that a lashing device is designed to sustain in normal use.

Coefficient of Friction – the friction between logs and the adjacent surfaces. This can vary significantly.

Load Strap is the term used in this guide to cover web-lashing, lashings, webbing straps, lashing straps. These are all terms used to describe the man-made fibre straps that are used for securing loads.

Tensioning device – This is usually a hand operated ratchet type device used with load straps.

Newton = SI (International System of Units) measurement of force, named after Isaac Newton. It is the force required to accelerate 1Kg of mass at the rate of 1 metre per second squared.

10 Newtons = **1 daN** (decanewton)

1,000 Newtons = 1 kN (Kilonewton)

1kN = 102 Kgf or 100Kg of load (102*9.81)

Example for typical ratchet tensioner;

S_{TF} of 400 daN. 400daN = 4,000 N = 4 kN = 408 Kgf (Kilogram Force)

S_{HF} of 50daN. 50daN = 500N = 0.5 kN = 51Kgf (Kilogram Force)

1. Responsibilities

1.1 Responsibilities – Haulier

It is the responsibility of the Haulier Operators Licence Holder or Employer;

- To provide a vehicle that is designed and suitable for the transport of round timber
- To ensure that the trailer is fitted with bunks or stanchions of a suitable strength for the load being carried
- To ensure that sufficient numbers of load straps and tensioners are provided and that there is adequate storage space for safely carrying the load straps when not in use
- To ensure that the load straps are suitably rated for the securing of round timber as specified in this guidance document and that they are tagged and are in good condition
- To ensure that straps are replaced when damaged or lost
- To ensure that, where a crane is fitted, it is inspected annually⁶ and the GA1 certificate is carried on the vehicle
- To ensure that the vehicle is maintained and serviced in accordance with the manufacturers and RSA guidelines⁷ and that records are maintained
- To ensure that defects reported by the driver are repaired as required
- To comply with all relevant Road Traffic and Road Transport legislation
- To provide adequate training and refresher training to the driver(s) and to ensure that the training is understood and implemented
- To carry out a risk assessment of the round timber transport operation and ensure that a safe system of work is put in place and observed by the drivers
- To provide and maintain personal protective equipment as required

1.2 Responsibilities - Driver

The driver is responsible for the vehicle and its load while on the road.

This Guideline contains specific instructions for drivers in relation to the transport of round timber. In addition, drivers should observe the following general duties;

- obey the rules of the road with particular regard to speed limits
- comply with drivers hours regulations and the working time directive
- adapt their driving to suit the weather and traffic conditions and road class
- drive in a careful manner and be considerate to other road users
- In regard to extracting timber from rural areas the following points should be observed;
 - o do not drive in convoy
 - o avoid critical times such as school opening and closing
 - o be aware of sensitive local events such as funerals
 - o avoid operating at night where possible as this can disrupt neighbours

Daily Checks. i.e. walk-around vehicle to inspect and report any defects, including defects on the load securing equipment – bunks, straps, tensioners. Please see the following example of a daily vehicle check;

⁶ Health and Safety Authority – Guide to the Safety, Health and Welfare at Work (General Application) Regulations – Use of Work Equipment
⁷ Road Safety Authority – Guide to Keeping your Vehicle Roadworthy

Driver: _____	Date: _____	Location: _____
Vehicle: _____	Trailer: _____	Odometer: _____
DAILY VEHICLE CHECK - Items to be checked by driver before and during driving - Function - Damage - Cleanliness etc. ✓ = Serviceable × = Defect		
Lamps/Indicators/Stoplamps	Tyres - inflation-damage-wear	Exhaust - condition-smoke-emission
Reflectors/Markers/Warning devices	Wheels - condition-security	Tachograph/Speedometer - operation
Battery - security-condition	Body/Guards/Wings/Spray suppression - damage	Speed limiter - operation
Mirrors - condition-security	Body/Load - security-protection	Trailer coupling - operation-condition
Brakes - pressure-operation-leaks	Number plates - condition-security-illumination	Trailer connections - condition-function-leaks
Brakes - warning devices and instruments	Horn/Wipers/Washers - operation-condition	Trailer landing legs - condition-operation
Driving controls/Steering -wear-operation	Engine oil/Water/Fuel - levels-leaks	Ancillary equipment - Loading aids, etc.
Tax Disc	CVRT	Insurance
Trailer Clean	Bark	Debris
Loading straps	Number	Condition
Bunks/stanchions	Condition	Cracks
If sliding bunks are used is the security apparatus is good condition?		Warning Triangle
If fitted with a crane		Fire Extinguisher
		Branches
		No loose items
		Frayed
		Damaged
		Knotted
		Damaged
		Leaning outwards
		Spillage Kit
		Certification expiry date
		Signs of leaks or damage?

Trailer Inspection

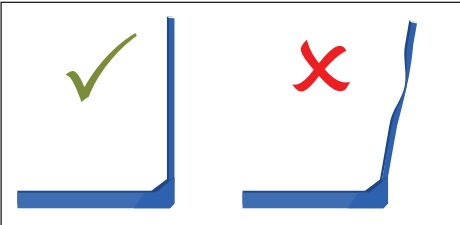
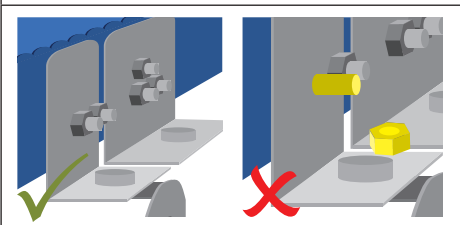
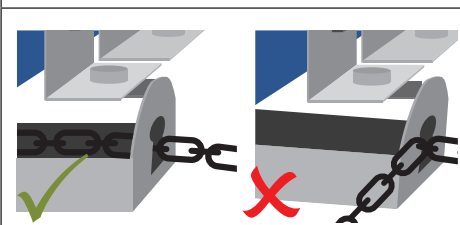
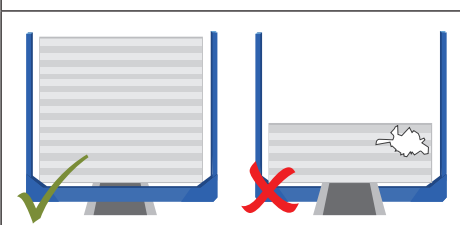
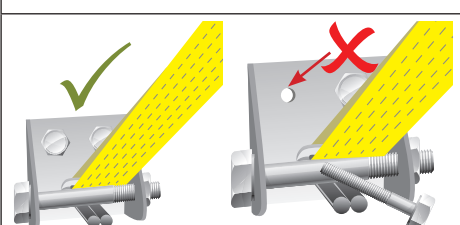
	<p>Inspect Stanchions to see that these are straight and not damaged, watching out for any signs of failure e.g. cracks</p>
	<p>Check that Stanchions are secured properly to the chassis and that all securing bolts are in place</p>
	<p>Check that Sliding Bunks can be secured properly with a fit for purpose locking mechanism</p>
	<p>Check that the Headboard is properly secured, not damaged and fit for purpose.</p>
	<p>Check that Lashing Points are properly secured, not damaged and fit for purpose.</p>

2. Vehicle Legal Requirements and Compliance

Rigid and Trailer

The vehicle should where possible be designed and plated to operate at 46 tonne gross vehicle weight in accordance with SI 136 of 2015⁸. In order to operate at 46 tonnes GVW these vehicles require;

Rigid vehicles and drawbar trailers already in service prior to 1st June 2015 require air suspension or equivalent systems and Electronic Braking Systems (EBS).

New rigid vehicles registered on or after 1st June 2015, in addition to requiring air suspension or equivalent systems and EBS, also require Electronic Stability Control (ESC). However, an exemption from the ESC requirement is provided for rigid vehicles having more than 3 axles.

New drawbar trailers licensed on or after 1st June 2015, in addition to requiring air suspension or equivalent systems and EBS, also require Roll Stability Control (RSC).

It is essential that the trailer is designed for 46 tonne GVW operation and should have a plated weight of at least 24 tonnes.

Articulated Vehicles

The vehicle should where possible be designed and plated to operate at 46 tonne gross vehicle weight in accordance with SI 43 of 2013⁹ as follows;

Tractor units and semi-trailers already in service at this time will require EBS braking systems in order to be permitted to operate as part of a 6 axle 46-tonne combination.

From 1st April 2013, new tractor units in such a combination (in addition to EBS braking systems) will require electronic stability control (ESC), while, from the same date, new semi-trailer units in such a combination (in addition to EBS braking systems) will require roll stability control.

The maximum permitted tonnes/metre allowance for semi-trailers that will operate as part of a 46 tonne combination is increased from 5.5t/m to 5.75t/m.

⁸ SI No 136 of 2015 Road Traffic (Construction and Use of Vehicles) (Amendment) Regulations 2015
⁹ SI No 43 of 2013 – Road Traffic (Construction and Use of Vehicles) (Amendment) Regulations 2013

Vehicle weights and dimensions (GVW)

The following are the maximum gross vehicle weights for the relevant vehicle combinations. These are the maximum permissible weights for these vehicle combinations and may be reduced if the plated weight of the vehicle is less. The plated weight of the vehicle must NOT be exceeded¹⁰.

Rigid and drawbar

Total Number of Axles	Combination	Maximum Gross Vehicle Weight
6	3 axles on the rigid and 3 axles on the trailer	46 tonne
5	3 axles on the rigid and 2 axles on the trailer	42 tonne
5	2 axles on the rigid and 3 axles on the trailer	40 tonne

Articulated

Total Number of Axles	Combination	Maximum Gross Vehicle Weight
6	3 axles on tractor and 3 axles on the semi-trailer	46 tonne
5	3 axles on tractor and 2 axles on the semi-trailer	42 tonne
5	2 axles on the tractor and 3 axles on the semi-trailer	40 tonne

These maximum gross vehicle weights may change over time. They are subject to a number of qualifying parameters and vehicle operators should consult the guidelines published on the RSA website.

Height

The maximum height of a vehicle including the load permitted under law is 4.65 meters. Operators and drivers should be aware of their own vehicle/load maximum height and any height restrictions such as from low bridges on the route.

General Compliance

Driver must observe all the rules of the road and other relevant legislation. There is a considerable amount of Road Transport and Road Traffic Legislation to be complied with as part of the transport operation. This includes;

- Road Freight Licence
- Vehicle Maintenance including ancillary equipment and CVRT
- Drivers Hours Regulations
- General Road Traffic laws as set out in the rules of the road

Driver competence

In addition to holding the appropriate driver licence and driver Certificate of Professional Competency (CPC), the driver should be trained on the following;

- Crane operation
- Load securing including securing of sliding bunks other relevant operations as required
- Records should be maintained of the training and refresher training provided as required

The driver should have an understanding of forest operations and driving on unsurfaced single carriageway forest roads.

10

Road Safety Authority - Guidelines on Maximum Weights and Dimensions of Mechanically Propelled Vehicles and Trailers, Including Manoeuvrability Criteria, July 2016

3. Load Securing Systems

3.1 Trailers

Skeletal Trailers

Skeletal trailers are purpose built for round timber haulage. They are designed to minimise tare weight, without floors but are fitted with suitable bunks for load securing.

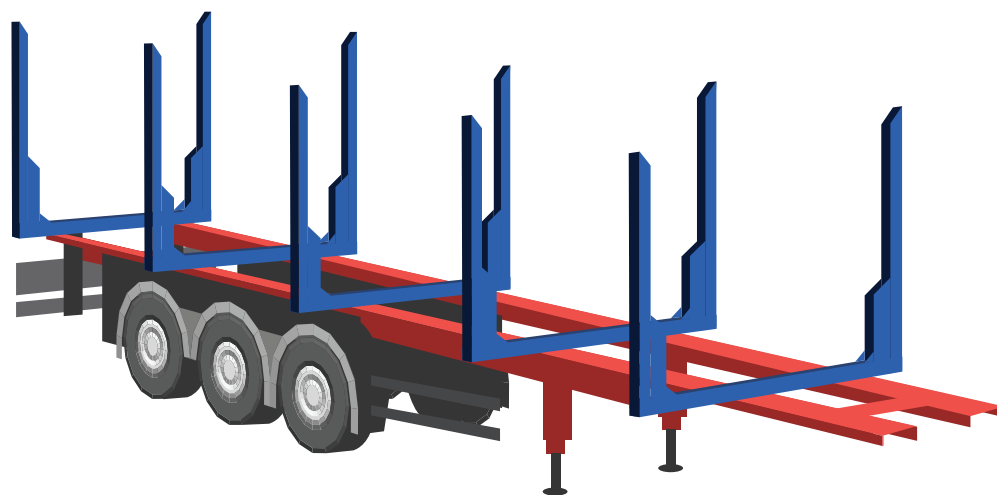

Flatbed Trailers with removable uprights

Some trailers are fitted with removable stanchions to facilitate the transport of other cargo such as sawn timber or pallets. In this case, the stanchions and the mounting socket should be designed to carry the load. As a general rule they should be designed so that, together, they can withstand a lateral force equivalent to 50% of the maximum load weight at half the load height above the vehicle platform.

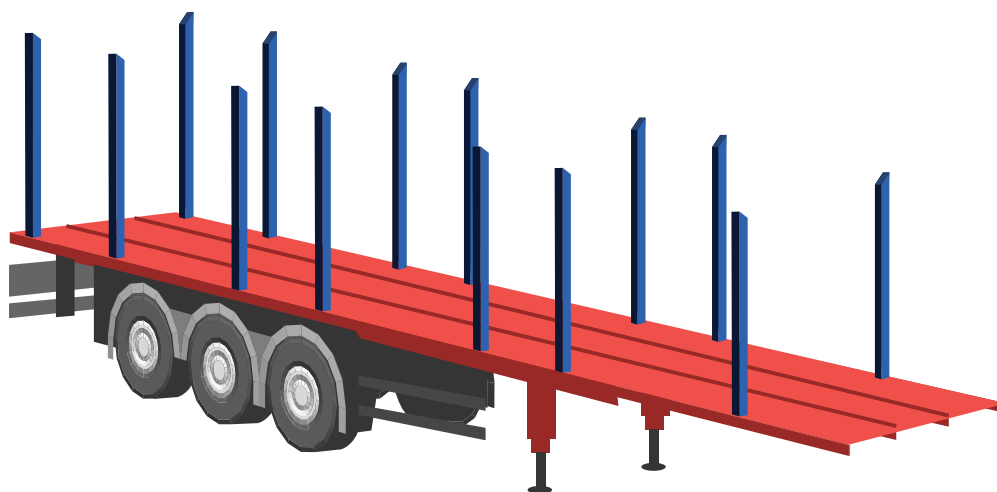

Stanchions and Sockets

Stanchions and sockets should be designed, fabricated and fitted by a competent person or company so that they are capable of withstanding the forces during the transport of timber.

Stanchions should always be vertical and not slope outwards beyond the width of the trailer.

If stanchions are cracked or become distorted they should be replaced or repaired.

Repairs should be carried out by a competent person and ensure they are of a satisfactory standard before being put back into service.



Unacceptable

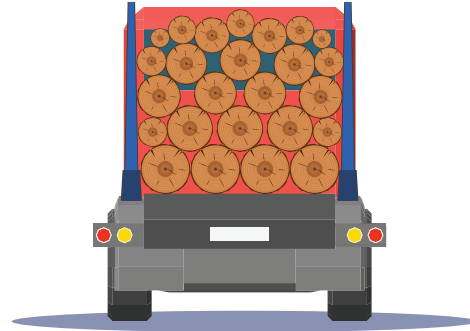

Good for use

Bunks

Bunk – a “U” shaped frame including uprights and a horizontal cross member for securing round timber. Bunks should be specifically designed for the transport of round timber. They should be rated to safely support a designated weight of timber.

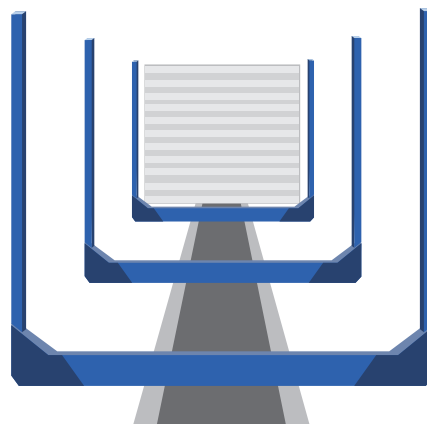

Bunks with Serrated Edge

It is recommended that they should have a serrated edge on the horizontal member to improve the friction between the timber and the bunk and that this be approx. 10 mm deep. This may also be achieved by welding side plates/strips to the cross members.

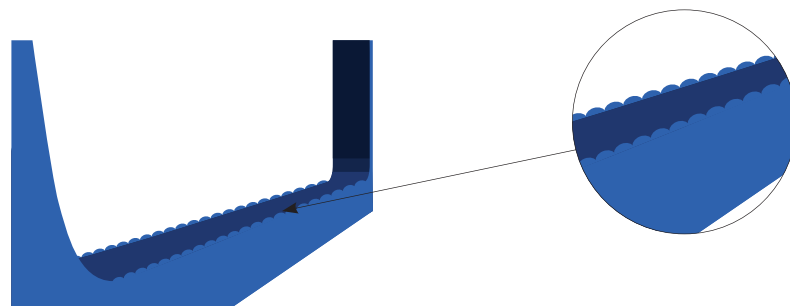

Sliding Bunks

Sliding bunks are fitted to some skeletal trailers to facilitate loading and also to reposition for different log lengths. Sliding bunks should be designed so that they can be securely prevented from moving in cases of severe braking when loaded. The securing should not be solely reliant on friction between the bunks and the chassis. A positive securing mechanism should be provided which can be easily and safely operated by the driver from the ground.



Lashing Points

Where load straps are anchored to the bottom flange of the chassis, the chassis should be designed to take the stresses resulting from this. The straps should be fixed in a way that prevents them sliding along the chassis in the case of severe braking. It is recommended that a series of designated lashing points should be provided and that these lashing points be positioned to facilitate the securing of various different lengths of timber.

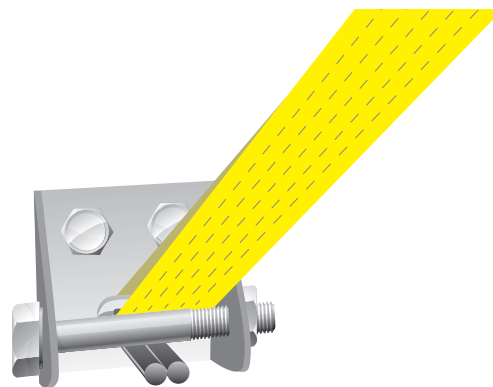

These lashing points should be of adequate strength, meeting the requirements of EN 12640, and be suitable and convenient for attaching the end of the ratchet straps.

Headboards

It is best practice that headboards, when fitted, are designed to meet the requirements of EN12642 and be capable of withstanding 80% of the load. The headboard should be the full height of load, where it is being relied on to restrain the load from moving forward.

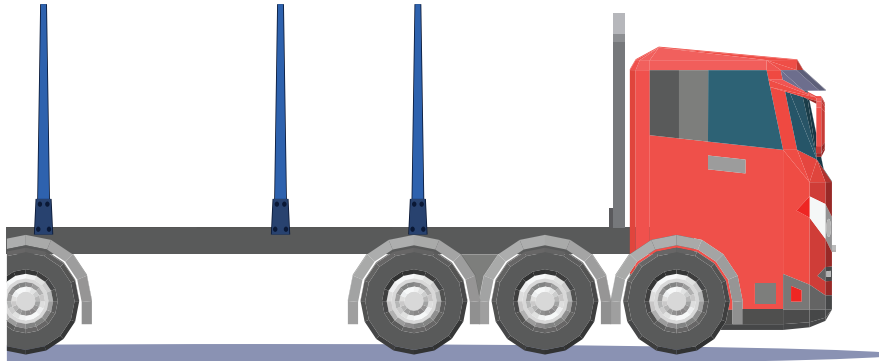

Cranes

Cranes when fitted should be designed for timber handling and have a suitable grab, fixed securely. The crane and its attachments must be installed and commissioned by a competent person.

Crane must be properly maintained, operate smoothly, no oil leakages, no undue wear on pins, bushings, hoses and no cracks in the structure.

Cranes are subject to certification in accordance with Safety, Health and Welfare at Work (General Application) Regulations 2007 – Chapter 2 – Use of Work Equipment.

Crane must be inspected annually and a certificate issued (GA1) by a competent person.

It is recommended that the crane is fitted with an overload protection device.

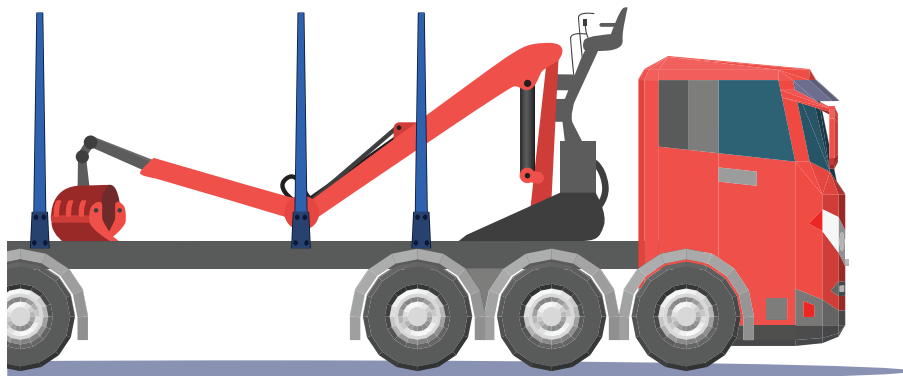

3.2 Load Securing Systems

Load Straps

All load straps should meet EN12195-2. Each individual load strap should have a tag showing the standard and the S_{TF} – the standard tension force. It is recommended that this should be a minimum of 400daN to allow this pre-tension to be applied. This is a very important factor in load securing as this tension serves to increase friction when using top over tie down lashings and thus prevent load movement.

Vehicles should have spare load straps on board at all times. The load straps should be stored securely on the vehicle.

Load straps should be of the correct length for the load and vehicle.

Excessively long lashings can result in the loose ends dangling from vehicles which can create a hazard for other road users

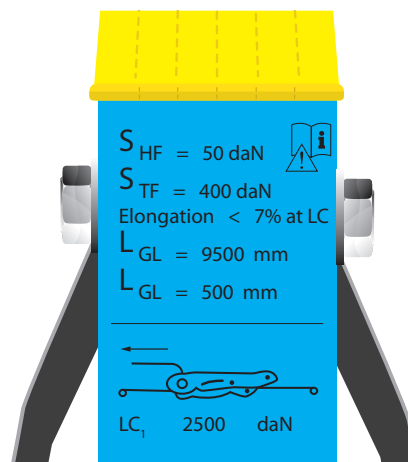

Strap Label S_{TF} 400 daN

Tensioning Device

A suitably rated ratchet type tensioner should be used with each strap. The tensioners are designed for hand operation only. Bars or levers should not be used as they may damage the device. The recommended standard tension force, S_{TF} is 400 daN. This provides a pre-tension of 400 daN while using the standard hand force (S_{HF} of 50 daN.)

Pre-tension is applied using the same standard hand tension force. Tensioners can provide different standard tension forces as a result of longer handle which provides more leverage and a greater number of teeth in the ratchet.

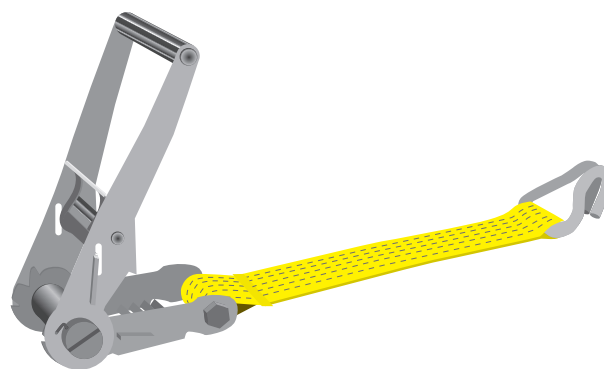

Ratchet Label; S_{HF} 50 daN, and S_{TF} of 400 daN

Chains

Chains are an alternative form of lashing, but are more difficult to use and could cause a serious accident, e.g. throwing a chain over the load and striking a person on the other side.

Chains, if used should meet EN-12195-3. When used with a suitable tensioner, these can provide very high tensions, e.g. 1,900 daN as shown below.

It is recommended that one chain lashing is carried on the vehicle, as a fall back, in order to cope with more difficult loads such as debarked timber or partially debarked fresh logs, particularly in spring time.

When chains are used, it is recommended that a light rope be used to pull the chain over the load.

Load binders that operate over centre are not recommended.

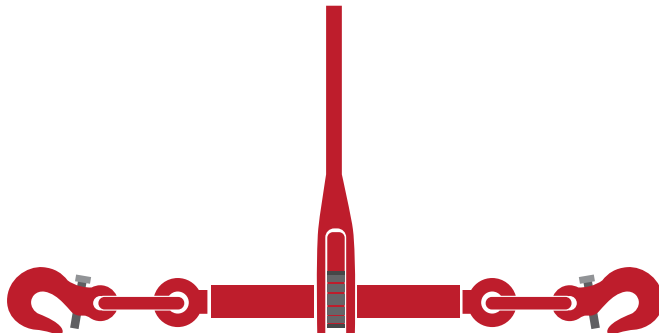

Ratchet Tensioner, S_{HF} 50daN

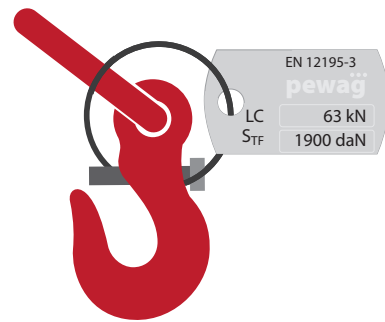

Steel Tag, showing S_{TF} of 1,900 daN

Load Strap and Tensioner Inspection

		<p>Check for tears, cuts, nicks and breaks in load bearing fibres and retaining stitches</p>
		<p>Check for knots</p>
		<p>Check for deformations, splits, pronounced signs of wear and signs of corrosion in the tensioning device (ratchet)</p>
		<p>Check that only legibly marked and labelled load straps and Tensioners are in use</p>

4. Loading Vehicles

Loading vehicles with logs is a high risk operation and can result in serious injury or even fatality. Loading can be carried out by the vehicle driver using the vehicle crane or alternatively by a third party. This may create additional hazards that must be considered in the risk assessment.

Risk Assessment

Consider the risks associated with each individual load and journey. These hazards and risks will vary depending on vehicle type, location, type of logs, weather etc.

Before commencing to load

- Always wear appropriate PPE
- Ensure that the outriggers are securely fixed, on firm ground or pads if required
- Check that the vehicle is in a straight line
- Look out for overhead power lines and plan accordingly
- Ensure that there are no drivers or other personnel within the work zone (The work zone should be at a minimum, the area within a radius of the fully extended crane plus half the length of the logs being loaded)
- Take care when accessing the crane particularly during wet or frosty weather. Ensure use of three points of contact at all times
- Ensure you have good visibility from the crane operators cabin (if fitted)
- If the vehicle is being loaded by another crane, ensure good communication between all parties involved

When Loading

You should be mindful of;

- Not creating an obstruction on the road
- Risk of being struck by logs, or logs striking something else
- Vehicle overturning due to poor ground or uneven loading
- Risks to other forest users
- Risk of being struck by another vehicle in the forest
- Do not attempt to start strapping until the loading operation is complete where there is a third party involved in the loading operation

Safe Loading

The load should be placed on the vehicle to ensure;

- the load can be restrained effectively
- the load does not de-stabilise the vehicle
- the load remains stable when applying and removing the lashings

The objectives when building a load are to;

- maximise the friction between the outer logs and the trailer bunks/stanchions
- ensure that contact between the internal logs is maximised

In order to achieve this, the crane operator should;

- Ensure that logs are neatly loaded into each bunk and there is an even projection beyond the uprights, at least 300 mm on each side
- Ensure that shorter logs should be securely contained within the load and not be at the edge
- Where logs are significantly tapered, it may be necessary to place logs head to toe for an even flat load
- Avoid gaps where possible

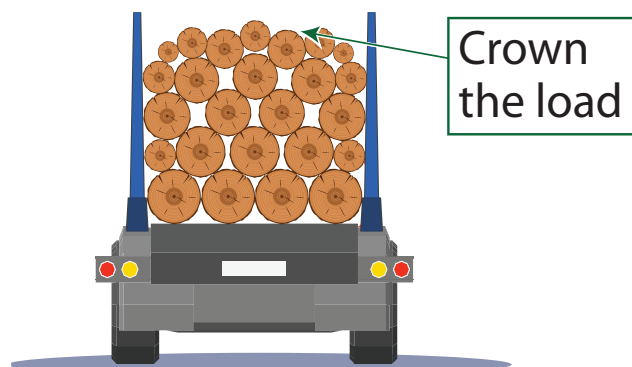
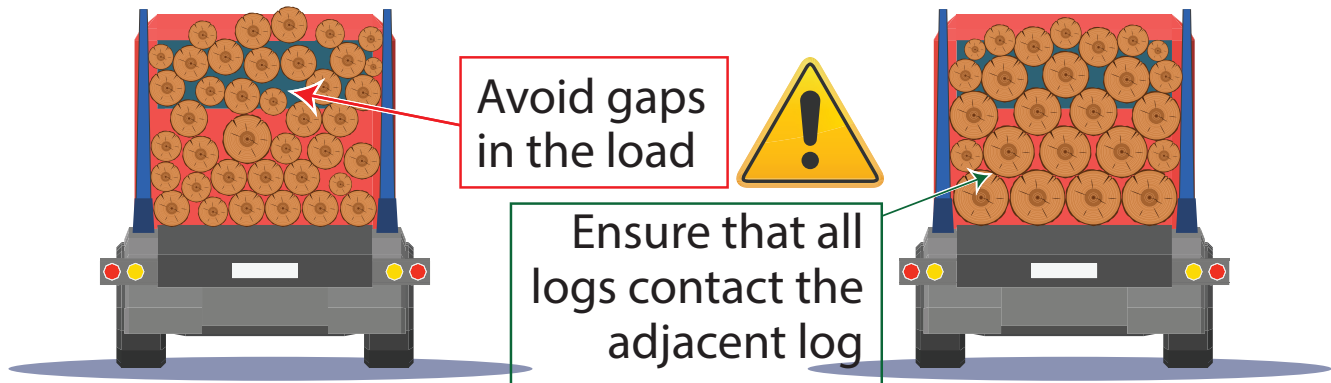

- Finish the top of the load with the crown as shown in sketch
- Logs should not project above the top of the upright by more than one third of the log diameter at this point
- Make sure that there are no loose branches, debris, or other material that might fall off or otherwise cause a hazard while travelling on the road
- In the case of a vehicle mounted crane, it is preferable that the logs are secured independently of the crane. If the crane is imbedded in the load and strapped with the logs, strapping must be such that all the logs are positively secured and held by the load straps

5. Securing the load

It is of critical importance to ensure that the load is secured before commencing the journey and that there is no risk to other road users or the general public as a result of logs falling off. In this respect, it is essential that all logs are secured, as even a single log falling off a vehicle could result in a serious or possibly fatal accident.

Strapping the Load

- Top over load straps create a vertical pressure on the timber, increasing the friction so as to prevent the logs from moving
- Use the recommended number of load straps to each bay of timber in accordance with this guidance. See below;
- Ensure that the load straps are in good condition, evenly spaced, as symmetrically as possible
- Ensure that the load straps and tensioner are securely attached to the lashing points or to the bottom web of the chassis
- Tighten each load strap using the tensioner provided using appropriate hand tension. Levers or bars should not be used in an effort to increase pre-tension as the ratchet tensioners are designed to achieve the standard tension forces using hand force only
- Ensure that any excess length of load strap is securely tied up so that this will not present a hazard to other road users such as pedal cyclists or motor cyclists

Vehicle with headboard

Where the vehicle is fitted with a headboard the load should be no higher than the headboard unless the necessary precautions have been taken to prevent it from moving forward.

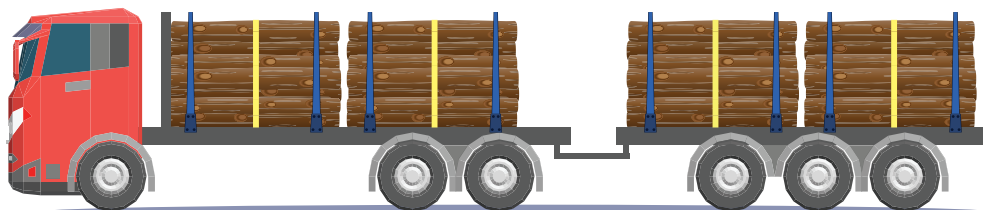

At least **one load strap per bay** if the logs are **up to a maximum length of 3.3 metres** with bark still present.

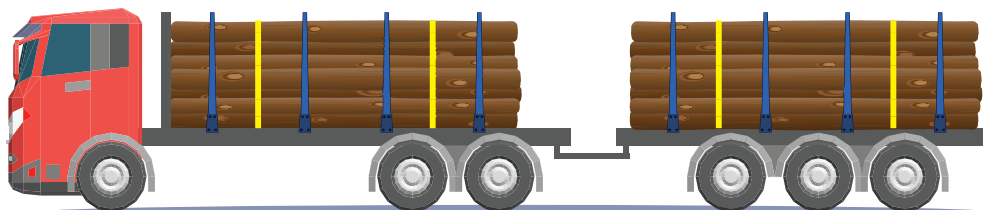

At least **two load straps per bay** if the logs are **longer than 3.3 metres** or irrespective of the length if the bark has been removed.

Vehicle without headboard

If the vehicle is not fitted with a headboard, or if the headboard is not of sufficient size or strength then load straps are needed as follows.

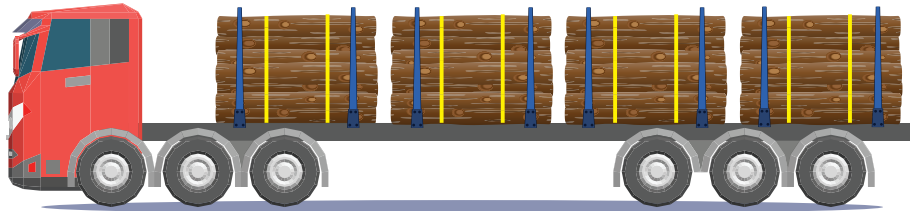

At least **two load straps per bay** if the logs are **up to a length of 3.3 metres**

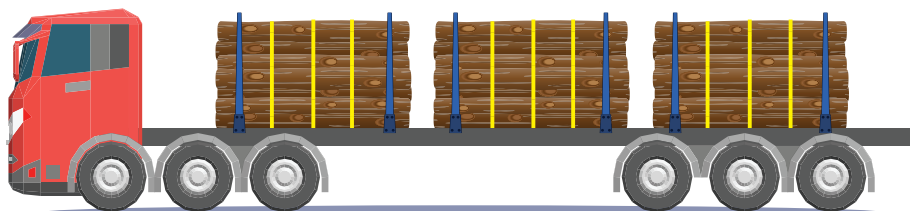

At least **three load straps per bay** if the logs are **greater than 3.3 metres and up to a length of 5.0 metres**

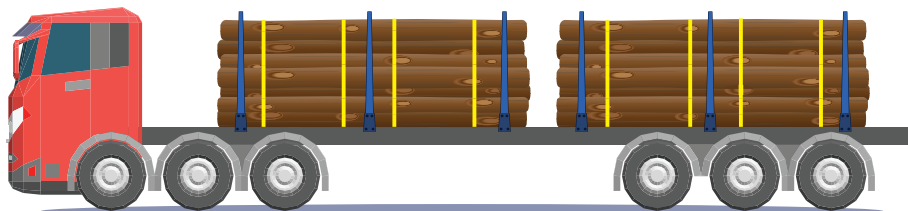

At least **four load straps per bay** if the logs are **longer than 5.0 metres**

Stakes

- Where short timbers are carried, e.g. stakes, then additional bunks or stanchions will be required to ensure that each bay is secured by two bunks or stanchions
- The number of load straps required will be as set out above for logs up to a length of 3.3 metres
- It is very difficult to secure short logs when loaded across the vehicle (transversely) on conventional timber haulage vehicles. Unless the truck/trailer has been modified for this purpose, this practice is not recommended

6. Transporting the Load from the Forest

Transporting logs from the forest can be a high risk activity which can result in serious injury or even fatality. The load security while in transit is the drivers responsibility.

Risk Assessment

Consider the risks associated with each journey when transporting a load from the forest. These hazards and risks will vary depending on vehicle type, road classification, type of logs, weather etc. The main hazards are;

- vehicle collisions
- truck roll over
- logs and other material falling off vehicles

Drivers should

- Be aware of the possible effect of a high centre of gravity and the risk of rollover at inappropriate speed, or in cases of severe road camber or degradation/failure of road.

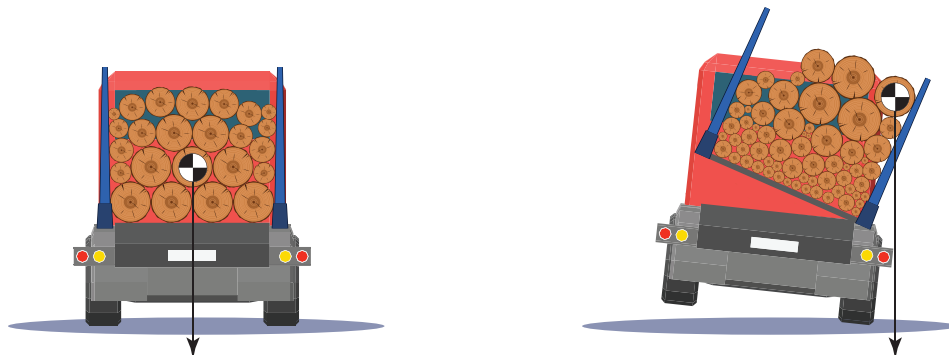

- Ensure that the vehicle is not overloaded (via load sensors, experience of similar loads, visual experience) and that the load is distributed as evenly as possible so that individual axle(s) are not overloaded
- When loaded, ensure that where sliding bunks are used, that they are positively locked in position before tying down and moving off

During the journey

- Take due caution and note associated risks when driving on unsurfaced narrow forest roads
- It is recommended to re-tension all load straps in the early part of the journey as the logs will “settle” as a result of the movement, causing load straps to lose their pre-tension
- Be aware of the overall height before travelling under low bridges
- Take due caution and note associated risks when driving on narrow country roads
- Observe the rules of the road
- Adapt their driving to suit weather and traffic and road conditions
- Be aware of general traffic hazards

7. Unloading Vehicles

Unloading logs from a vehicle is a high risk activity which can result in serious injury or even death to those involved including vehicle driver, crane operator and others in the vicinity.

Risk Assessment

Consider the risks associated with unloading each individual load. These hazards and risks will vary depending on vehicle type, location, type of logs, weather etc. The main hazards are;

- being struck by a log
- being struck by another passing vehicle
- being struck by a crane
- striking others while handling logs
- creating an obstruction

Arriving at the destination

Once you arrive at the unloading facility, you are required to follow the rules of the site. You may need to complete an induction prior to entering the facility. Each site may be different but you should familiarise yourself with the following;

- process for weighing or estimating your load (use of keyfob, etc.)
- the paperwork you may need to submit
- where to park so that you can remove the load straps safely
- where to stand when your vehicle is being off loaded
- who is in charge
- first aid, emergency response and incident management plans

Unstrapping the load

The driver should proceed to the unstrapping area when it is free. Before commencing any work put on the required PPE. Inspect the load for hazards. These may include logs that have moved or broken since you last secured the load straps. If you are concerned that the load is unsafe or may become unsafe during unstrapping, ask the supervisor for help.

- remove tension from the load straps
- unhook the tensioners
- separate the tensioners from the straps
- collect the tensioners and proceed to the other side of the vehicle
- pull the straps to check they are free
- carefully pull the straps off the load
- watch the top of the load for any log movement
- if the straps become snagged in the logs, do not attempt to climb on the load, get help to free the load strap
- roll up the straps and stow carefully with the tensioners in the designated storage area on the vehicle

Unloading and stacking out

- proceed to the unloading zone with the load unstrapped
- await permission to enter the unloading area
- secure truck and move into the safe zone (this may be defined on site, otherwise stay well out of the working area of the unloading machine)
- leave the safe zone only when it is safe to do so
- Remove any debris from the vehicle in the designated area before exiting the site

When unloading is being carried out by another vehicle, it may be necessary to move the crane (if fitted) away from the load before commencing the removal. Safely position vehicle crane so that it will not obstruct the unloading of the logs.

Note-the unloading operator should not commence unloading until the driver is in the designated safe zone.

Clean the trailer of any loose debris before commencing on the next journey.

References

Forest Industry Transport Group – Managing Timber Transport, Good Practice Guide, 2014

Health and Safety Authority – Load Safety Series, Information Sheet on Safe Load Securing of Round Timber

Health and Safety Authority/IRU – International Guidelines on Safe Load Securing for Road Transport, February 2017

Health and Safety Authority – Guide to the Safety, Health and Welfare at Work (General Application) Regulations – Use of Work Equipment

Road Safety Authority – Guide to Keeping your Vehicle Roadworthy

Road Safety Authority - Guidelines on Maximum Weights and Dimensions of Mechanically Propelled Vehicles and Trailers, Including Manoeuvrability Criteria, July 2016

European Best Practice Guidelines on Cargo Securing for Road Transport, 2014

Health and Safety Laboratory – Load Safe, Road Safe, a professional driver's guide to safe loading and transport

Health and Safety Laboratory – Transport Safety, an operator's guide to safe loading and transport

UK Department for Transport – Code of Practice – Safety of Loads on Vehicles

Timber Transport Forum – Road Haulage of Round Timber, Code of Practice

Forest Works ISC (Australia) – Log Haulage Manual – Techniques for Loading, Driving and Unloading Trucks that Carry Logs and other Forest Produce, Version 1, August 2014

Log Transport Safety Council (New Zealand) – Log Load Securing Requirements Version 2, 2012

Legislation and Standards

SI No 190 of 1963 – Road Traffic (Construction, Equipment and Use of Vehicles) Regulations 1963
SI No 5 of 2003 – Road Traffic (Construction and Use of Vehicles) Regulations 2003
SI No 366 of 2008, Road Traffic (Construction and Use of Vehicles) (Amendment) Regulations 2008
SI No 136 of 2015 Road Traffic (Construction and Use of Vehicles) (Amendment) Regulations 2015
SI No 43 of 2013 – Road Traffic (Construction and Use of Vehicles) (Amendment) Regulations 2013

Directive 2014/47/EU on the technical roadside inspection of the roadworthiness of commercial vehicles circulating in the Union and repealing Directive 2000 /30/EC

EN Standards

EN 12195 -1:2003 – Load restraining on road vehicles – safety – Part 1: Calculation of securing forces
EN 12195-2 2000 – Load restraint assemblies on road vehicles, Part 2 web lashings made form man-made fibres
EN 12195 – 3:2001 – Load restraint assemblies on road vehicles – safety – Part 3: Lashing Chains

Websites

Road Safety Authority www.rsa.ie
Health and Safety Authority www.hsa.ie

UK Driver and Vehicle Standards Agency (DVSA)

<https://www.gov.uk/government/publications/load-securing-vehicle-operator-guidance/load-securing-vehicle-operator-guidance#why-load-securing-is-important>

UK Health and Safety Laboratory
<http://www.hsl.gov.uk/products/transport-safety/driver-responsibility>

UK Health and Safety Executive
<http://www.hse.gov.uk/workplacetransport/loadsafty/index.htm>

Timber Transport Forum – www.timbertransportforum.co.uk

